



*Most Widely Accepted and Trusted*

# ICC-ES Evaluation Report

## ESR-2147

ICC-ES | (800) 423-6587 | (562) 699-0543 | [www.icc-es.org](http://www.icc-es.org)

Reissued 05/2019

This report is subject to renewal 05/2020.

**DIVISION: 31 00 00—EARTHWORK**

**SECTION: 31 60 00—SPECIAL FOUNDATIONS AND LOAD-BEARING ELEMENTS**

**REPORT HOLDER:**

**AG-CO PRODUCTS, INC.**

**EVALUATION SUBJECT:**

**AG-CO FP-10, FP-12, FP-16 AND FP-24 MOLDED COMPOSITE FOOTING PADS**



*“2014 Recipient of Prestigious Western States Seismic Policy Council (WSSPC) Award in Excellence”*



*ICC-ES Evaluation Reports are not to be construed as representing aesthetics or any other attributes not specifically addressed, nor are they to be construed as an endorsement of the subject of the report or a recommendation for its use. There is no warranty by ICC Evaluation Service, LLC, express or implied, as to any finding or other matter in this report, or as to any product covered by the report.*



# ICC-ES Evaluation Report

**ESR-2147**

Reissued May 2019

This report is subject to renewal May 2020.

[www.icc-es.org](http://www.icc-es.org) | (800) 423-6587 | (562) 699-0543

A Subsidiary of the International Code Council®

**DIVISION: 31 00 00—EARTHWORK**  
**Section: 31 60 00—Special Foundations and Load-Bearing Elements**

**REPORT HOLDER:**

**AG-CO PRODUCTS, INC.**

**EVALUATION SUBJECT:**

**AG-CO FP-10, FP-12, FP-16 AND FP-24 MOLDED COMPOSITE FOOTING PADS**

**1.0 EVALUATION SCOPE**

**Compliance with the following codes:**

- 2018, 2015, 2012, 2009 and 2006 *International Building Code*® (IBC)
- 2018, 2015, 2012, 2009 and 2006 *International Residential Code*® (IRC)

**Properties evaluated:**

- Structural
- Durability

**2.0 USES**

The AG-CO FP-10, FP-12, FP-16 and FP-24 molded composite footing pads are footings for the support of a wood or precast concrete post column in buildings for Type V construction under the IBC or any construction under the IRC. The molded composite footing pads are used as individual, isolated footings supporting gravity loads only.

**3.0 DESCRIPTION**

**3.1 General:**

The AG-CO molded composite footing pads are circular, ribbed-plastic pads formed by an injection molding process. See Figures 1, 2, 3 and 4 for dimensions and rib configurations.

**3.2 Material:**

The AG-CO footing pads are made from a proprietary composite of engineered polypropylene and fiberglass.

**4.0 DESIGN AND INSTALLATION**

**4.1 Design:**

The AG-CO footing pads are designed as shallow rigid footings that transmit, uniformly to the supporting soil, the applied gravity load imposed by a minimum 3<sup>1</sup>/<sub>2</sub> inch by 3<sup>1</sup>/<sub>2</sub> inch (89 mm by 89 mm) post on the FP-10 pad, a minimum 3<sup>1</sup>/<sub>2</sub>-inch-by-3<sup>1</sup>/<sub>2</sub>-inch (89-mm-by-89-mm) post

on the FP-12 pad, a minimum 4<sup>1</sup>/<sub>2</sub> inch by 5<sup>1</sup>/<sub>2</sub> inch (114 mm by 140 mm) post on the FP-16 pad, and a minimum 4<sup>1</sup>/<sub>2</sub>-inch-by-5<sup>1</sup>/<sub>2</sub>-inch (114-mm-by-140-mm) post on the FP-24 pad. Allowable loads are controlled by the type of supporting soil. AG-CO footing pad design loads must not exceed the allowable gravity loads shown in Table 1.

**4.2 Installation:**

The post location or spacing must be determined by the loads imposed on the post and the allowable AG-CO footing pad design load for the specific type of soil (see Table 1). The post hole must be slightly larger than the footing pad diameter and deep enough to satisfy all design requirements. The bottom of the hole must be flattened and leveled to provide a uniform bearing surface for the footing pad. The AG-CO footing pad must be placed into the hole with the flat side down. The footer pad must be tamped until level and stable in the bottom of the hole. The square-cut-post end must be positioned as close as possible to the center of the footer pad and the post must be plumbed. The dirt around the post must be placed in 12-inch lifts (30.5 cm), tamping each lift tamped before more soil is added.

**5.0 CONDITIONS OF USE**

The AG-CO FP-10, FP-12, FP-16 and FP-24 molded composite footing pads described in this report comply with, or are suitable alternatives to what is specified in, those codes listed in Section 1.0 of this report, subject to the following conditions:

- 5.1** Installation must comply with this report, the applicable code and the manufacturer's published installation instructions. If there is a conflict between the manufacturer's installation instructions and this report, this report governs.
- 5.2** The AG-CO molded composite footing pads are used to support wood or precast concrete posts for Type V construction under the IBC or any construction under the IRC.
- 5.3** The AG-CO molded composite footing pads must be installed below the frost line of the locality.
- 5.4** The AG-CO molded composite footing pads must be used as individual isolated footings to resist bearing loads only and must not be used to resist lateral or uplift loads.
- 5.5** Mechanical fasteners must not be used with the AG-CO molded composite footing pads unless the specific fasteners have been evaluated for use in contact with preservative-treated wood posts (AC257), concrete posts, composite footing pad and the ground.

- 5.6 Design calculations in accordance with Chapter 18 of the IBC or Chapter 4 of the IRC for the structure supported by the AG-CO molded composite footing pads must be submitted to the code official. The design must take into consideration the spacing of the footings.
- 5.7 The allowable soil bearing pressure and vertical movement for the AG-CO molded composite footing pad must be determined by a site-specific geotechnical investigation or evaluation in accordance with Section 1803 of the IBC or Section R401.4 of the IRC. When required by the applicable code, ageotechnical investigation or evaluation must be submitted to the code official for approval.

**6.0 EVIDENCE SUBMITTED**

Data in accordance with the ICC-ES Acceptance Criteria for Molded Composite Footing Pads (AC49), dated August 2013 (editorially revised January 2019).

**7.0 IDENTIFICATION**

- 7.1 Each pad must have a permanent label or etching including the name of the manufacturer, the model number and the evaluation report number (ESR-2147).
- 7.2 The report holder's contact information is the following:

**AG-CO PRODUCTS, INC.**  
**701 WEST STATE STREET, SUITE A**  
**SAINT JOHNS, MICHIGAN 48879**  
**(800) 522-2426**  
[www.footingpad.com](http://www.footingpad.com)

**TABLE 1—ALLOWABLE LOADS (POUNDS)**

IDENTIFICATION	PAD DIAMETER	1500 psf SOIL CAPACITY	3000 psf SOIL CAPACITY
FP-10	10 inch	810 lbs.	1622 lbs.
FP-12	12 inch	1126 lbs	2356 lbs
FP-16	16 inch	2009 lbs.	4200 lbs.
FP-24	24 inch	4013 lbs.	9327 lbs.

For SI: 1 inch = 25.4 mm; 1 lbf = 4.4 N; 1 lbf/ft<sup>2</sup> = 47.9 Pa.

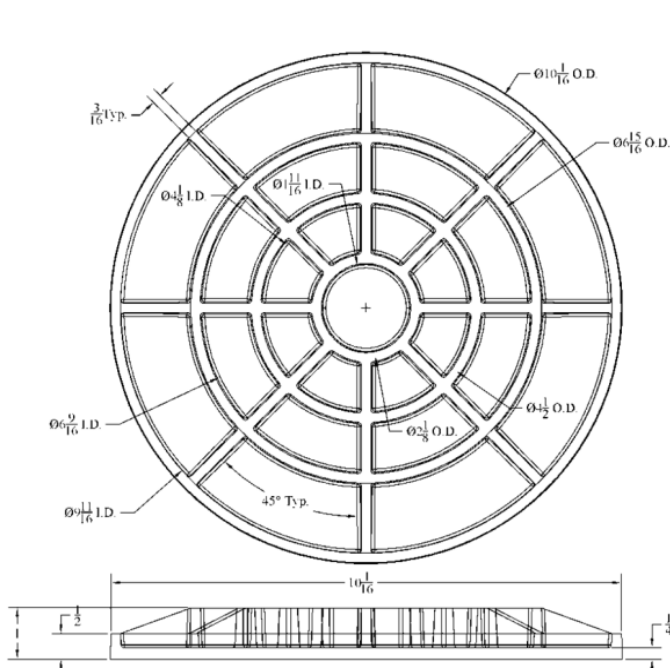

(All Dimensions in inches)  
**FIGURE 1—FP-10 FOOTER PAD**

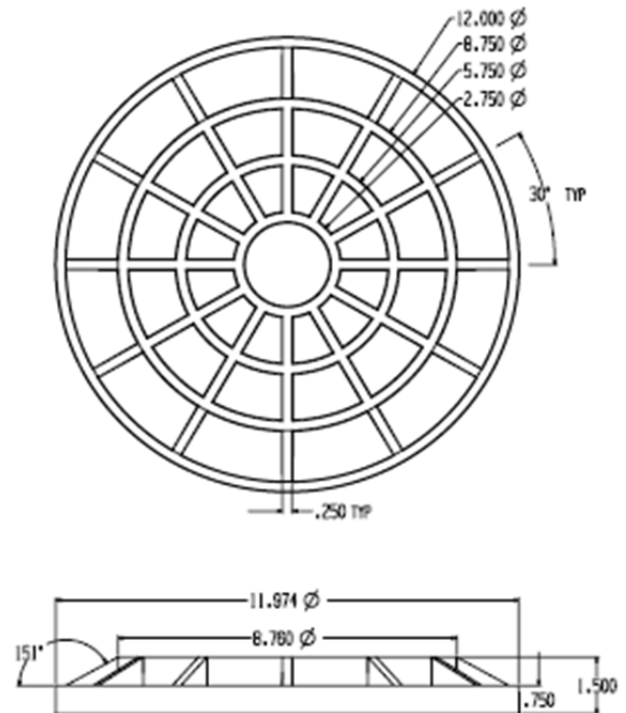

(All dimensions in inches)  
**FIGURE 2—FP-12 FOOTER PAD**

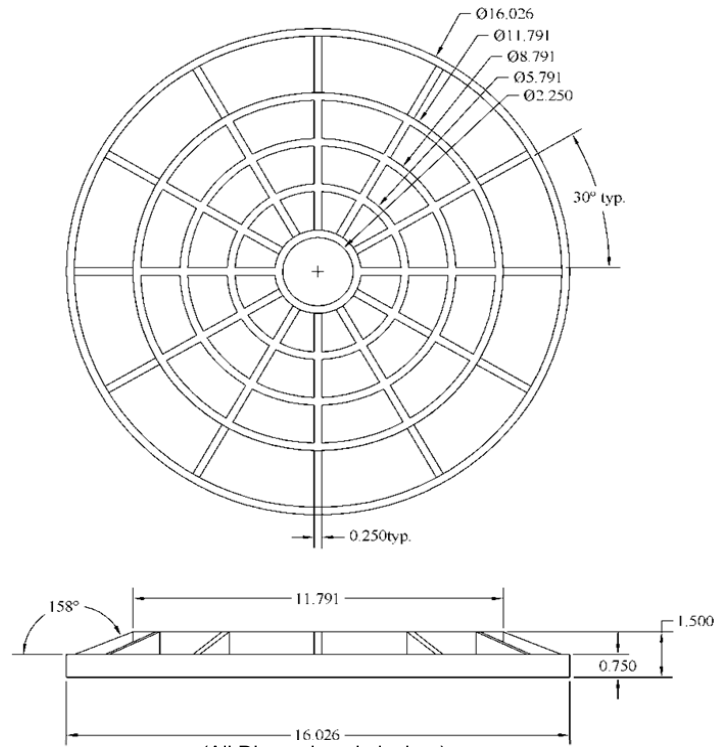

(All Dimensions in inches)  
**FIGURE 3—FP-16 FOOTER PAD**

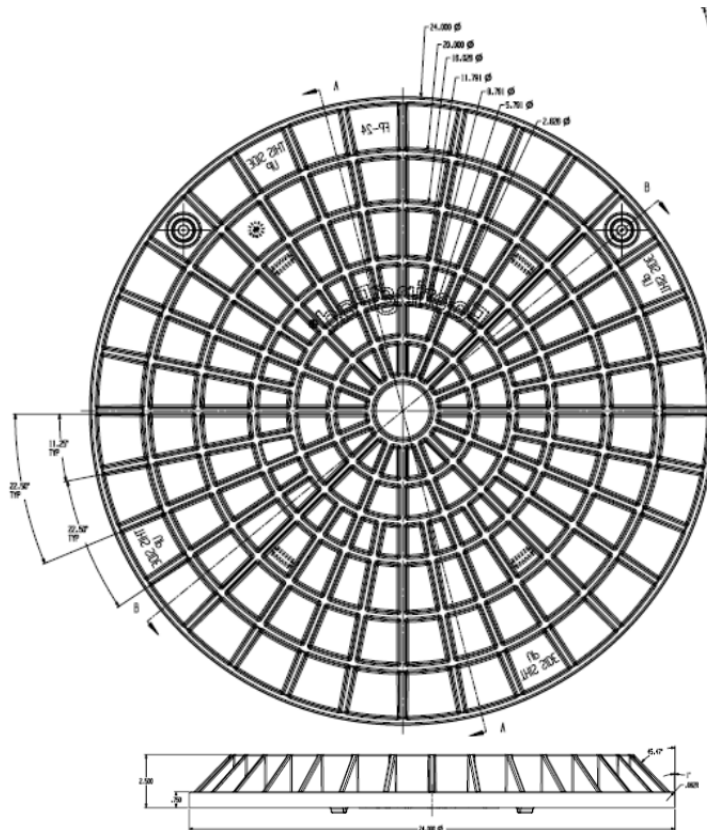

(All Dimensions in inches)  
**FIGURE 4—FP-24 FOOTER PAD**