

Midwest Perma-Column, Inc.

7407 N. Kickapoo Edwards Rd, Edwards, IL, 61528, Ph: 800-798-5562 Fax:309-589-1199
Licencee Manufacturer of Perma-Columns™

Non Standard Length Perma-Columns

(Lead time required for non standard columns)

cost adder

6 foot lengths

35 %

7 foot lengths

40 %

Metal Building Column

SC 1012 10" x 12" x 84" Metal Frame Building Column
5 per pallet @ 975 lb/column

Deck Columns

DP4440 Deck Post, 4" x 4" Solid Post with Powder Coat Bracket
Concrete Dimensions – 3 1/2" x 3 7/8" x 40" long
40 per pallet @ 54 lb/column

DP6640 Deck Post, 6" x 6" Solid Post with Powder Coat Bracket
Concrete Dimensions – 6 3/8" x 5 1/2" x 40" long
24 per pallet @ 127 lb/column

DP6430 Deck Post, RSawn Post with Powder Coat Bracket (6.125 width)
Concrete Dimensions – 6 3/8" x 5 1/2" x 30" long
24 per pallet @ 100 lb/column

Interior Wall Brackets

Interior Wall Brackets are used in non-structural applications where it is desired to keep wood columns or frameworks from moving or shifting. These are economical brackets and have a primed paint finish.

AB33 Angle Bracket - 3/16 x 3 x 3 x 3

AB44 Angle Bracket - 1/4 x 4 x 4 x 4

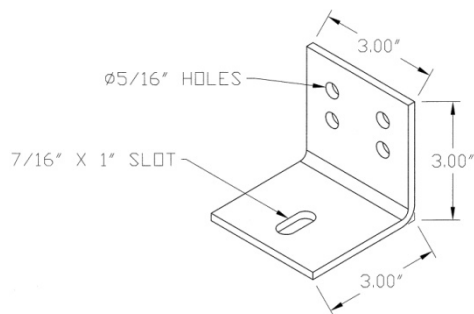

AB33

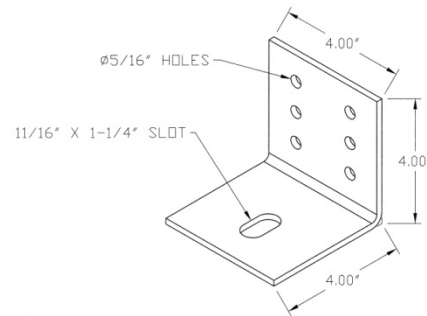

AB44

Midwest Perma-Column, Inc.

7407 N. Kickapoo Edwards Rd, Edwards, IL, 61528, Ph: 800-798-5562 Fax:309-589-1199
 Licencee Manufacturer of Perma-Columns™

Quantity Hardware Pricing

Item #	Drive Anchors & Screws	Material	Used With
PC2.5DHGS	3/16 x 2 1/2" Concrete Anchor (pre-drill with 3/16 masonry bit)	Galvanized Steel	Used to attach skirt boards
PC3DASS	1/4" x 3" Drive Anchor-roundhead (pre-drill with 1/4 masonry bit)	Stainless Steel	Used to attach skirt boards

PC3WF.TStar	1/4" x 3" WD Fastener with T-Star 30 torx drive - plated	Grade 5 Steel	As used in all Hardware packages
PC2.5WF.TStar	1/4" x 2.5" WD Fastener with T-Star 30 torx drive - plated	Grade 5 Steel	Recommended for use with deck posts

Wood Column to Bracket Attachment Hardware Packages – Perma-Column & Sturdi-Wall

Note: Drive Anchors for attaching the skirt board to the Perma-Columns are not included in the packages and must be purchased separately. On average, approximately 4 pieces are needed per Perma-Column per skirt board.

PK46US	Attachment Hardware for use with 4"x 6" Solid Post.		
<u>Part No.</u>	<u>Qty</u>	<u>Description</u>	
B5	2	1/2" x 5" Grade 5 Bolt Zinc	
FW	2	1/2" Flat Washer Galvanized	
FN	2	1/2" Serrated Flange Nut Zinc	
PC3WF	4	1/4"x 3" WD Fastener Plated	

PK66US	Attachment Hardware for use with 6"x 6" Solid Post.		
<u>Part No.</u>	<u>Qty</u>	<u>Description</u>	
B7	2	1/2" x 7" Grade 5 Bolt Zinc	
FW	2	1/2" Flat Washer Galvanized	
FN	2	1/2" Serrated Flange Nut Zinc	
PC3WF	4	1/4"x 3" WD Fastener Plated	

PK66UHDGS	Attachment Hardware for use with 6"x 6" Solid Post Hot Dipped Galvanized Hardware for Exposed Columns (using Grade 2 Bolts)		
<u>Part No.</u>	<u>Qty</u>	<u>Description</u>	
B7HDG	2	1/2 " x 7" Grade 2 Bolt Galvanized	
LWHDG	2	1/2" Lock Washer Galvanized	
FWHDG	4	1/2" Flat Washer Galvanized	
FNHDG	2	1/2" – 13 Hot Dipped Galvanized Steel Nut	
PC3WF	4	1/4"x 3" WD Fastener Plated	

- All prices are FOB Edwards, IL
- Terms are cash or certified funds on receipt.
- Prices and terms subject to change without notice.

Midwest Perma-Column, Inc.

7407 N. Kickapoo Edwards Rd, Edwards, IL, 61528, Ph: 800-798-5562 Fax:309-589-1199
Licencee Manufacturer of Perma-Columns™

page 5

Wood Column to Bracket Attachment Hardware Packages – Perma-Column & Sturdi-Wall

Note: Drive Anchors for attaching the skirt board to the Perma-Columns are not included in the packages and must be purchased separately. On average, approximately 4 pieces are needed per Perma-Column per skirt board.

PK63US	Attachment Hardware for use with 3 Ply – 2"x 6" Column.	
<u>Part No.</u>	<u>Qty</u>	<u>Description</u>
B6	2	½"x 6" Grade 5 Bolt Zinc
FW	2	½" Flat Washer Galvanized
FN	2	½" Serrated Flange Nut Zinc
PC3WF	4	¼"x 3" WD Fastener Plated

PK64US	Attachment Hardware for use with 4 Ply – 2"x 6" Column.	
<u>Part No.</u>	<u>Qty</u>	<u>Description</u>
B7.5	2	½"x 7.5" Grade 5 Bolt Zinc
FW	2	½" Flat Washer Galvanized
FN	2	½" Serrated Flange Nut Zinc
PC3WF	4	¼"x 3" WD Fastener Plated

PK83US	Attachment Hardware for use with 3 Ply – 2"x 8" Column.	
<u>Part No.</u>	<u>Qty</u>	<u>Description</u>
B6	2	½"x 6" Grade 5 Bolt Zinc
FW	2	½" Flat Washer Galvanized
FN	2	½" Serrated Flange Nut Zinc
PC3WF	8	¼"x 3" WD Fastener Plated

PK84US	Attachment Hardware for use with 4 Ply – 2"x 8" Column.	
<u>Part No.</u>	<u>Qty</u>	<u>Description</u>
B7.5	2	½"x 7.5" Grade 5 Bolt
FW	2	½" Flat Washer Galvanized
FN	2	½" Serrated Flange Nut Zinc
PC3WF	8	¼"x 3" WD Fastener Plated

PK85US	Attachment Hardware for use with 5 Ply – 2"x 8" Column.	
<u>Part No.</u>	<u>Qty</u>	<u>Description</u>
B9	2	½"x 9.0" Grade 5 Bolt
FW	2	½" Flat Washer Galvanized
FN	2	½" Serrated Flange Nut Zinc
PC3WFG	8	7"x 3" Galvanized Power Grip Screw

Midwest Perma-Column, Inc.

7407 N. Kickapoo Edwards Rd, Edwards, IL, 61528, Ph: 800-798-5562 Fax:309-589-1199
 Licencee Manufacturer of Perma-Columns™

*Uplift Hardware Package Details for Perma-Columns

PKS6	Standard uplift system *recommended for use with 6" Perma-Columns		
<u>Part No.</u>	<u>Qty</u>	<u>Description</u>	
B6.5	1	6.5" Grade 5 Bolt Zinc	
FN	1	½" Serrated Flange Nut Zinc	
FW	1	½" Galvanized Flat Washer	
PC20UA	2	Standard Uplift Anchors - 2 x 2 x 8 ½ x 0.134 Galvanized Steel	

PKS8	Standard uplift system that can be used with 8" Perma-Columns		
<u>Part No.</u>	<u>Qty</u>	<u>Description</u>	
B8.5	1	8.5" Grade 5 Bolt Zinc	
FN	1	½" Serrated Flange Nut Zinc	
FW	1	½" Galvanized Flat Washer	
PC20UA	2	Standard Uplift Anchors - 2 x 2 x 8 ½ x 0.134 Galvanized Steel	

PKM6	Medium uplift system that can be used with 6" Perma-Columns		
<u>Part No.</u>	<u>Qty</u>	<u>Description</u>	
B6.5	1	6.5" Grade 5 Bolt Zinc	
FN	1	½" Serrated Flange Nut Zinc	
FW	1	½" Galvanized Flat Washer	
PC25UA	2	Medium Uplift Anchors - 2 x 2 x 12 x 0.134 Galvanized Steel	

PKM8	Medium uplift system used with 8" Perma-Columns *recommended for use with PC8300, PC8300J, PC8400 & PC8500		
<u>Part No.</u>	<u>Qty</u>	<u>Description</u>	
B8.5	1	8.5" Grade 5 Bolt Zinc	
FN	1	½" Serrated Flange Nut Zinc	
FW	1	½" Galvanized Flat Washer	
PC25UA	2	Medium Uplift Anchors - 2 x 2 x 12 x 0.134 Galvanized Steel	

PKH8	Heavy uplift system used with 8" Perma-Columns *recommended for use with PC8400 & PC8500		
<u>Part No.</u>	<u>Qty</u>	<u>Description</u>	
B8.5	1	8.5" Grade 5 Bolt Zinc	
FN	1	½" Serrated Flange Nut Zinc	
PC30UA	2	Heavy Uplift Anchors - 3 x 3 x 12 x 0.250 Black Angle Iron	

Item #	Uplift Anchors	Material	*Recommended for
PC20UA	Light Uplift Anchor 2 x 2 x 8 ½ x 0.134	Galvanized Steel	PC4600, PC6600,PC6300, PC6400 & PC6300J
PC25UA	Medium Uplift Anchor 2 x 2 x 12 x 0.134	Galvanized Steel	PC8300 & PC8300J PC8400 & PC8500
PC30UA	Heavy Uplift Anchor 3 x 3 x 12 x 0.250	Black Angle Iron	PC8400 & PC8500

PC21UA	Wood Uplift Anchor 2 x 2 x 8 ½ x 0.134 (designed with 5 nail holes)	Galvanized Steel	Used on wood columns

*Uplift Hardware Package Details for Perma-Columns

Column Extender Hardware Package Details

PK12CE-6	Use with 6" <u>Perma-Columns</u>	
<u>Part No.</u>	<u>Qty</u>	<u>Description</u>
B6.5	1	6.5" Grade 5 Bolt Zinc
FN	1	½" Serrated Flange Nut Zinc
FW	1	½" Galvanized Flat Washer
PC12CE	1	Universal 12" Extension

PK12CE-8	Use with 8" <u>Perma-Columns</u>	
<u>Part No.</u>	<u>Qty</u>	<u>Description</u>
B8.5	1	½"x 8.5" Grade 5 Bolt Zinc
FN	1	½" Serrated Flange Nut Zinc
FW	1	½" Galvanized Flat Washer
PC12CE	1	Universal 12" Extension

PK24CE-6	Use with 6" <u>Perma-Columns</u>	
<u>Part No.</u>	<u>Qty</u>	<u>Description</u>
B6.5	1	6.5" Grade 5 Bolt Zinc
FN	1	½" Serrated Flange Nut Zinc
FW	1	½" Galvanized Flat Washer
PC24CE	1	Universal 24" Extension

PK24CE-8	Use with 8" <u>Perma-Columns</u> .	
<u>Part No.</u>	<u>Qty</u>	<u>Description</u>
B8.5	1	8.5" Grade 5 Bolt
FN	1	½" Serrated Flange Nut Zinc
FW	1	½" Galvanized Flat Washer
PC24CE	1	Universal 24" Extension

PK24HCE-8	Use with 8" <u>Perma-Columns</u> .	
<u>Part No.</u>	<u>Qty</u>	<u>Description</u>
B8.5	2	8.5" Grade 5 Bolt
FN	2	½" Serrated Flange Nut Zinc
FW	2	½" Galvanized Flat Washer
PC24CE	1	Universal 24" Extension

Item #	Extenders	Material
PC12CE	Universal 12" Extension	A36 Bent Plate
PC24CE	Universal 24" Extension	A36 Bent Plate
PC24HCE-8	Universal 24" Extension w/ Brace	

* Refer to the **Perma-Column Design and Use Guide** for optional uplift protection methods. The **Perma-Column Design and Use Guide** is a guide only and is not a replacement for a structural engineer. A structural engineer should always make the final recommendations based on building design.

Steel to Concrete Connection for Anchor Brackets – Sturdi-Wall

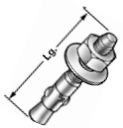
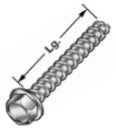
Item #		<u>Anchor Options*</u>	Drill Size
Wet Set Anchor “L” Bolt			
SWWS5-10		5/8-11 x 10” long includes nut and washer	Hot Dipped Galvanized 5/8”
Expansion Anchors			
SWEA4-6		1/2 -13 x 5½” long includes nut and washer	Hot Dipped Galvanized 1/2”
SWEA5-6		5/8-11 x 6” long includes nut and washer	Hot Dipped Galvanized 5/8”
Screw Anchors			
SWSA3-4		3/8 x 4” long	Zinc-Plated 3/8”
SWSA4-4		1/2 x 4” long	Zinc-Plated 1/2”
SWSA5-5		5/8 x 5” long	Zinc-Plated 5/8”
SWSA5-6		5/8 x 6” long	Zinc-Plated 5/8”
SWSA5-6G		5/8 x 6” long	Galvanized 5/8”
SWSA5-6.5		5/8 x 6½” long	Zinc-Plated 5/8”

* Refer to the **Sturdi-Wall Design Manual** for details on the load values and installation of the various anchor systems. The **Sturdi-Wall Design Manual** is a guide only and is not a replacement for a structural engineer. A structural engineer should always make the final recommendations based on building design.

- All prices are FOB Edwards, IL
- Terms are cash or certified funds on receipt.
- Prices and terms subject to change without notice.